

FEATURES

- Accuracy $\pm 0.02PF$ (AP), $\pm 1^\circ$ (AU)
- Excellent long term stability (4~20mA, 750 Ω)
- Precision measurement even for unbalance system
- Precision measurement even for distorted wave
- High impulse & surge protection (5KV)
- The case can be mounted on a 35mm rail which complies with DIN 46277



OUTPUT

DC Output Range	Load Resistance	Output Resistance	Output Ripple	Response Time	
-1~0~1V	$\geq 500 \Omega$	$\leq 0.05 \Omega$	$\leq 0.5\% RO.$ (peak)	$\leq 400mS.$ 0~99%	
-5~0~5V	$\geq 500 \Omega$				
1~3~5V	$\geq 500 \Omega$				
0~5~10V	$\geq 500 \Omega$				
-1~0~1mA	0~10K Ω				$\geq 20M \Omega$
-10~0~10mA	0~1K Ω				$\geq 5M \Omega$
0~10~20mA	0~750 Ω				
4~12~20mA	0~750 Ω				

Remark: If DC source, the output: 0~20mA (0~500 Ω)
4~20mA (0~500 Ω)

Accuracy:	$\pm 0.02 PF$ (AP SERIES) $\pm 1^\circ$ (AU SERIES)
Input frequency:	50HZ $\pm 3\%$ or 60HZ $\pm 3\%$
Input burden:	$\leq 0.2VA$ (ampere input) $\leq 0.1VA$ (voltage input)
Aux. power supply:	AC 110V $\pm 5\%$, 50/60HZ AC 220V $\pm 5\%$, 50/60HZ DC 24V, 48V, 110V, $\pm 15\%$, -10%
Power effect:	$\leq 0.01 PF$ (AP), $\leq 0.5^\circ$ (AU)
Power consumption:	$\leq 4VA, \leq DC 3W$
Waveform effect:	$\leq 0.02 PF$ (AP), $\leq 1^\circ$ (AU) at distortion factor, 30%
Output load effect:	Current output $\leq 0.1\% RO.$ Voltage output $\leq 0.05\% RO.$
Magnetic field strength:	400A/M. $\leq 0.02PF$ (AP), $\leq 1^\circ$ (AU)
Span adjustment range:	$\geq 5\% RO.$
Zero adjustment range:	$\geq 1\% RO.$
Operating temperature range:	0~60 $^\circ C$
Storage temperature range:	-10~70 $^\circ C$
Temperature coefficient:	$\leq 0.02PF$ (AP), $\leq 1^\circ$ (AU)
Max. relative humidity:	95%
Isolation:	Input/output/power/case
Insulation resistance:	$\geq 100M\Omega$, DC 500V
Dielectric withstand voltage:	Between input/output/power/case
(IEC 414, 688, ANSI, C37)	AC 3KV, 60HZ, 1 min.
Impulse withstand test:	5KV, 1.2 X 50us
(IEC 255-4, ANSI C37 90a)	Common mode & differential mode
Performance:	Designed to comply with IEC688
Safety requirements:	IEC 414, BS5458

DESCRIPTION

Model: AP-1 for 1 ϕ 2W, power factor (COS θ)
 AP-3 for 3 ϕ 3W, power factor (COS θ)
 AP-3A for 3 ϕ 4W, power factor (COS θ)
 AU-1 for 1 ϕ 2W, Phase angle (ϕ)
 AU-3 for 3 ϕ 3W, Phase angle (ϕ)
 AU-3A for 3 ϕ 4W, Phase angle (ϕ)

These transducers require an auxiliary power supply and offer a highly accurate method of measuring the phase angle of the input. They have a full four quadrant capability. The output is a linear function of the phase angle between the two inputs (which can be current or voltage), the circuit can also be used as power factor transducer only added a COS θ circuit. Output amplifier provides constant voltage or current output. Output is unaffected by load resistance provided it is within the specified range.

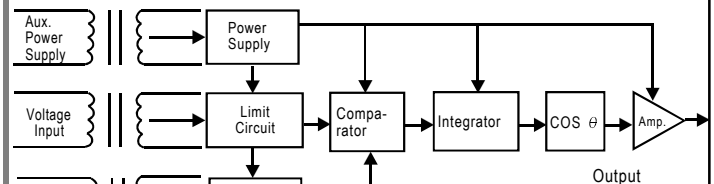

INPUT-OUTPUT CURVE

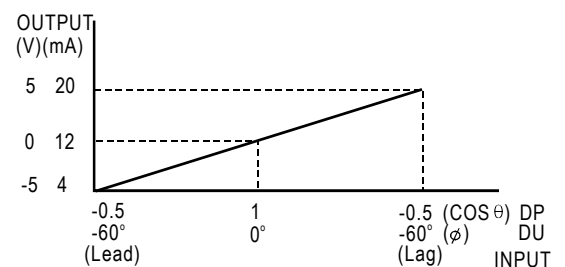

SPECIFICATION

INPUT

Input Range				Max. Input Over Capability
Circuit	Amp	Voltage	Range	
Single Phase	5A	110V(120V)	(Lead) (Lag)	Ampere: 3 X rated continuous 10 X rated 10 sec. 50 X rated 1 sec. Voltage: 1.5 X rated continuous 2X rated 10 sec. 4X rated 2 sec.
		220V(240V)		
3-Phase 3-Wire	5A	110V(120V)	0.5 ~ 1 ~ 0.5	
		220V(240V)		
3-Phase 4-Wire	5A	190V/120V (208/120V)	(Lead) (Lag)	
		380V/220V (416/240V)		

POWER FACTOR, PHASE ANGLE TRANSDUCER

ORDERING MODEL MAKE UP

AP-1
AP-3
AP-3A
AU-1
AU-3
AU-3A

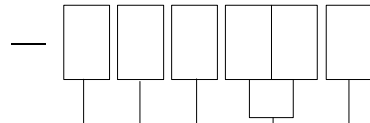

Model

AP-1 for 1 ϕ 2W, power factor
AP-3 for 3 ϕ 3W, power factor
AP-3A for 3 ϕ 4W, power factor
AU-3 for 1 ϕ 2W, Phase angle
AU-3 for 3 ϕ 3W, Phase angle
AU-3A for 3 ϕ 4W, Phase angle

Input Current

5: 5A
O: Option

Input voltage

1: 110V (120V)
2: 220V (240V)
3: 190V/110V (208V/120V)
4: 380V/220V (416V/240V)
O: Option

Input Frequency

5: 50HZ \pm 3HZ
6: 60HZ \pm 3HZ
O: Option

Out Range

V1: -1 ~ 0 ~ 1V	A1: -1 ~ 0 ~ 1mA
V2: -5 ~ 0 ~ 5V	A2: -10 ~ 0 ~ 10mA
V3: 1 ~ 3 ~ 5V	A3: 0 ~ 10 ~ 20mA
V4: 0 ~ 5 ~ 10V	A4: 4 ~ 12 ~ 20mA
O: Option	

Aux. Power Supply

A: AC110V	C: DC 24V
B: AC220V	D: DC 48V
O: Option	E: DC 110V

THE OUTSIDE DIMENSION

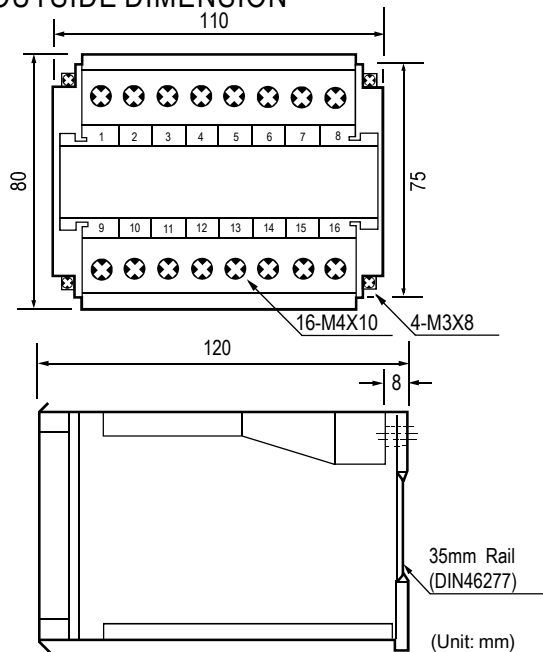

PANEL MOUNTING HOLES

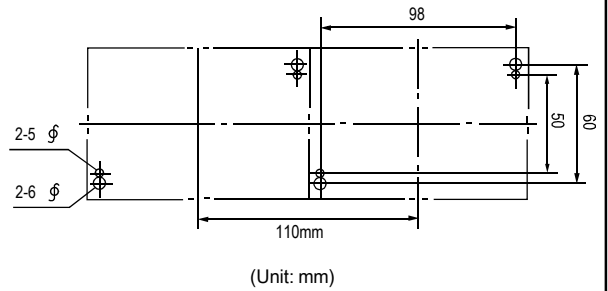

CONNECTION DIAGRAM

AP-1,AU-1 (1 ϕ 2W)

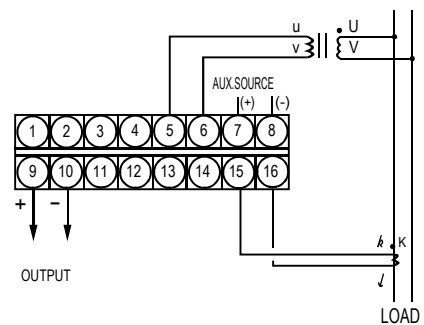

AP-3,AU-3 (3 ϕ 3W)

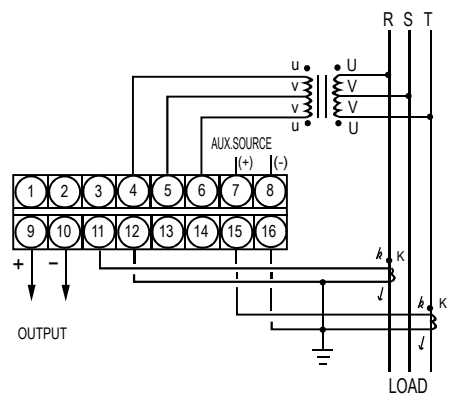

AP-3A,AU-3A (3 ϕ 4W)

